

THE VIEWFINDER

SAAC Photography Competition

CALL FOR ENTRY

Cash Prizes • **DEADLINE FEBRUARY 1** • Exhibit February 5 - March 3, 2024
AWARDS RECEPTION • Thursday, February 15, 2024 • **5:30-7:00PM**

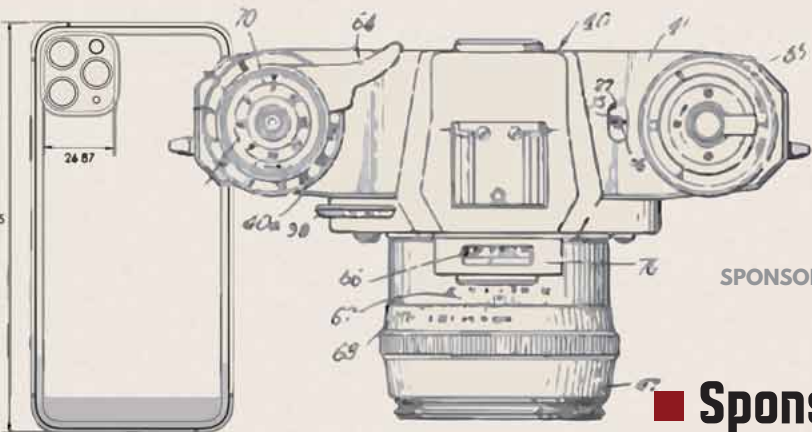

\$1200 in PRIZE MONEY

■ Best in Show: \$500



■ 1st: \$250

■ 2nd: \$150

■ 3rd: \$50

SPONSORED BY



■ Sponsor's Purchase Award: \$250

New! for Best Union County Photo

It's time to see Union County shine! Take this opportunity to grab your camera and showcase the beauty and drama of Union County's unique architecture, landscapes, and people.

ENTER up to **TWO FRAMED PHOTOGRAPHS** created with any type of camera, printed on any media. Basic corrective editing is allowed, but no graphic manipulations. Entries can not have previously shown in The ViewFinder.

DELIVER entries to the South Arkansas Arts Center by Thursday, February 1st.

FEE to enter is \$10 for each piece. SAAC members get one free entry.

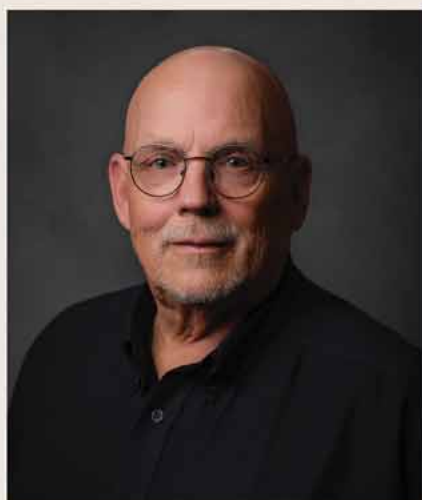

JUDGE • GREG OWENS

Professional Photographer and owner of Owens Image & Design



THE VIEWFINDER 2024 COMPETITION PROSPECTUS

CALENDAR

Entry DEADLINE February 1
 Show Opening February 5
 Artist Reception February 15
 5:30-7:00pm Artist Reception
 6:00pm Awards Presentation
 Last Day of Exhibit March 3
 PICK-UP Art Work March 4

JUDGE: Greg Owens, Professional Photographer and owner of Owens Image & Design in El Dorado, Arkansas

ENTRY/FEE: Limit 2 pieces per person with an entry fee of \$10 each. SAAC members can enter one photograph for free.

AWARDS: Cash prizes will be awarded to the Best of Show (\$500), First Place (\$250), Second Place (\$100), and Third Place (\$50)

ELIGIBILITY: Photographs can be take with any type of camera and printed on any medium. Basic corrective editing in the dark room or digitally on the computer is allowed but no graphic manipulations. Photographs must have not previously shown in past ViewFinder Competitions. Each piece must be ready for display in the gallery with a sufficient hanging method. The judge and show chairperson have final authority to define what constitutes an acceptable entry.

DELIVERY DEADLINE & PICK-UP DATES: Works must be delivered to SAAC by February 1 and picked up on March 4. Artists are responsible for the delivery and pickup of all works. Shipped pieces must include a return shipping instructions when received. Work not picked up after 30 days will become the property of SAAC.

EXHIBITION: All works will be on exhibit in SAAC's Galleries February 4 - March 1, 2024. An Artist Reception will be held February 15, 5:30-7:00pm with an awards presentation at 6:00pm. All work must remain for the duration of the exhibit.

SALES: Sales are encouraged. A 35% commission will be charged on all sales resulting from the exhibition. Works NOT FOR SALE must be marked NFS.

WAIVER: Any work submitted may be reproduced for promotional purposes by the South Arkansas Arts Center, El Dorado Insider, or The Diamond Agency. All prize winners will need to provide the original photo or digital file so a high resolution, print-ready file can be made for sponsor's use. The receipt of an entry in the competition will constitute agreement by the artist with all conditions set forth in the prospectus.

SPONSOR'S PURCHASE AWARD \$250 for Best Union County Photo: Photos taken in Union County are also eligible for the new Sponsor's Purchase Award. If your entry is selected by the sponsors as the best Union County photo submitted to the competition, you will receive an additional \$250 cash prize separate from the judge's awards. Your entry will become part of The Diamond Agency's artwork collection, and the image will be featured in an upcoming edition of the "El Dorado Insider" publication.



South Arkansas
 Arts Center
 110 East 5th Street
 El Dorado, AR 71730
 870-862-5474
 www.saac-arts.org

Name: _____

Address: _____

City, State, Zip: _____

Phone: _____

E-mail: _____

THE VIEWFINDER 2024 ENTRY FORM

I hereby certify that the entry described here is my original unaltered photography. I have read and fully understand the rules of the competition and agree to allow the artwork to be reproduced for promotional purposes.

Artist's Signature

Entry Title: _____

Camera/
 Medium _____

Price: Eligible for Best Union County Photo Sponsor's Purchase Award Prize

Entry Title: _____

Camera/
 Medium _____

Price: Eligible for Best Union County Photo Sponsor's Purchase Award Prize

ATTACH LABEL TO ENTRY OR WRITE CONTACT INFO ON BACK OF FRAME

Title _____

Artist _____

Email or
 Phone _____

ATTACH LABEL TO ENTRY OR WRITE CONTACT INFO ON BACK OF FRAME

Title _____

Artist _____

Email or
 Phone _____